

Magna/al



FEATURES

- Fluorescent system provides energy savings up to 50% when compared to HID.
- Multi voltage electronic ballast resistant to brownouts or voltage and frequency fluctuations.
- Heavy duty lens and housing.
- Full length flange on base allows for direct mounting.
- Optional slide-in mounting bracket for ease of removal.
- Tool less entry via heavy duty twist draw latches.
- Lens frame hinged on side for easy lamp replacement.
- UV and impact resistant polycarbonate lens.
- Extruded aluminum lens frame, seam welded.
- Neoprene gasket resists petroleum.
- Spring loaded lamp holders, for linear lamps resist shock and vibration.
- Optional self contained emergency battery backup ballasts.
- Optional certified test switch on emergency models.
- Optional long life T5 lamps available upon request (consult factory).

APPLICATIONS

- Hazardous locations
- Oil and gas exploration and production
- Waste water treatment plants
- Pipeline compressor / pumping & storage
- Maintenance & lubrication pits
- Petrochemical facilities
- High abuse areas

APPROVALS

- Class I Division 2 - Groups A, B, C, & D
- Class I Zone 2 - Groups IIA, IIB & IIC
- Class II Division 2 - Groups F & G
- Class III
- Type 4

STANDARDS

- UL 844 - Hazardous Locations
- UL 1598 - Luminaires
- CSA - Class 3428 03
- CSA - Class 3428 83

TECHNICAL SPECIFICATIONS

HOUSING

Extruded aluminum with cast end caps.

LENS

0.125 inch thick clear polycarbonate.

REFLECTOR

Copper free aluminum with a white gloss finish.

GASKET

One piece neoprene.

MOUNTING

Direct via full length flange. Optional slide style kit.

LATCHES

Plated steel twist draw.

LAMP HOLDER

Spring loaded on one or both ends for linear lamp types.

ENTRIES

1/2" NPT feed-through outlets, optional 3/4" NPT outlets.

LAMP TYPES

See ORDERING REFERENCES. Lamps not provided.

BALLAST

120 to 277 volt 50/60 Hz electronic standard, optional 347v and 480v.

EMERGENCY BATTERY BACKUP BALLAST

Optional, self contained 90 minute minimum for all lamp types. Starting temperature 32°F/0°C.

ORDERING REFERENCES

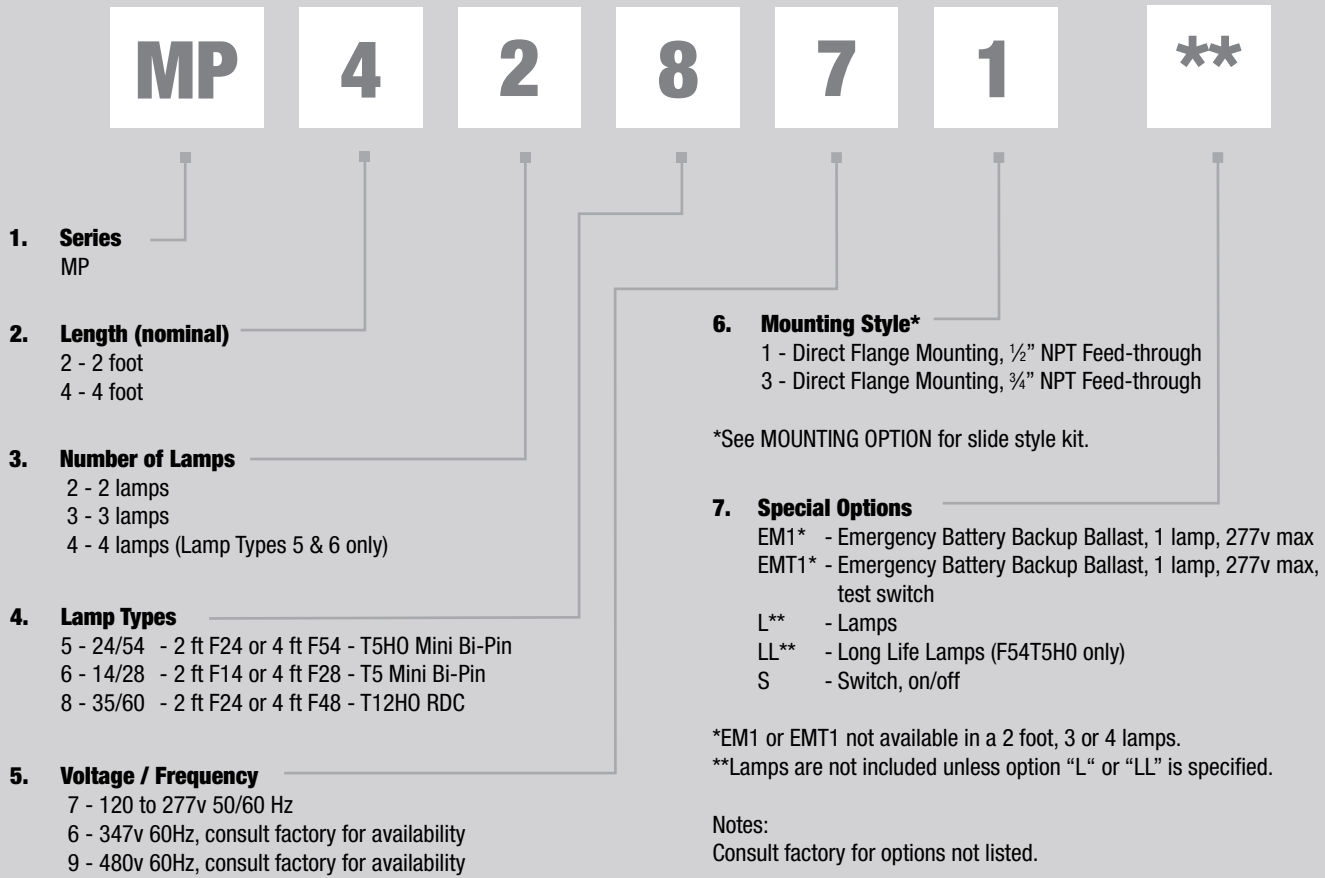

SPARE PARTS

Part No.	Description
FX5350	BALLAST 120-277V AC 50/60HZ, 1 x 14, F14T5
FX5307	BALLAST 120-277V AC 50/60HZ, 1 x 24, F24T5HO
FX5350	BALLAST 120-277V AC 50/60HZ, 1 x 28, F28T5
FX5307	BALLAST 120-277V AC 50/60HZ, 1 x 24, F24T5HO
FX5334	BALLAST 120-277V AC 50/60HZ, 1 x 35, F24T12HO
FX5305	BALLAST 120-277V AC 50/60HZ, 1 x 54, F54T5HO
FX5334	BALLAST 120-277V AC 50/60HZ, 1 x 60, F48T12HO
FX5350	BALLAST 120-277V AC 50/60HZ, 2 x 14, F14T5
FX5307	BALLAST 120-277V AC 50/60HZ, 2 x 24, F24T5HO
FX5350	BALLAST 120-277V AC 50/60HZ, 2 x 28, F28T5
FX5334	BALLAST 120-277V AC 50/60HZ, 2 x 35, F24T12HO
FX5305	BALLAST 120-277V AC 50/60HZ, 2 X 54, F54T5HO
FX5334	BALLAST 120-277V AC 50/60HZ, 2 x 60, F48T12HO
FX5128HDU	EMERGENCY BATTERY BACKUP BALLAST, EM1/EMT1, 120v-277v, CF, T8HO & T12HO
FX5346HDU	EMERGENCY BATTERY BACKUP BALLAST, EM1/EMT1, 120v-277v, T5 & T5HO
FX3573	LAMP, 14w, F14T5

Part No.	Description
FX3568	LAMP, 24w, F24T5HO
FX3574	LAMP, 28w, F28T5
FX3507	LAMP, 35w, F24T12HO
FX3567	LAMP, 54w, F54T5HO
FX3577	LAMP, 54w, Long Life F54T5HO
FX3505	LAMP, 60w, F48T12HO
005-4000	DOOR FRAME ASSEMBLY, 4 ft. models
005-2000	DOOR FRAME ASSEMBLY, 2 ft. models
005-4100	LENS, POLYCARBONATE, 4 ft. models
005-2100	LENS, POLYCARBONATE, 2 ft. models
005-4201	GASKET, neoprene, 4 ft. models
005-2201	GASKET, neoprene, 2 ft. models
005-4301	REFLECTOR, 4 ft. models
005-2301	REFLECTOR, 2 ft. models, HO model
758-0523	LAMP HOLDER, RDC, spring loaded HO models
754-0005	LAMP HOLDER, T5 HO fixed & spring set
035-1060	LATCH ASSEMBLY

HazMax Magna/al

TEMPERATURE CODES & APPROVALS

Lamp Wattage	Ballast/Socket Type	ANSI Lamp Code	Class I T-Code	Class I Division 2	Class II Division 2	Class III	Class II & III T-Code	Starting Temp	Maximum Ambient*	Supply Wire
14/28	T5 Mini Bi-Pin G5	F14/F28-T5	T4A	A,B,C & D	F & G	Yes	T3C	0°F / -18°C	55°C	90°C
24/54	T5HO Mini Bi-Pin G5	F24/F54-T5HO	T4A	A,B,C & D	F & G	Yes	T3C	-20°F / -29°C	55°C	90°C
35/60	T12HO RDC R17d	F24/F48-T12HO	T4	A,B,C & D	F & G	Yes	T3C	-20°F / -29°C	55°C	90°C

*Consult factory for optional higher ambient models.

DIMENSIONS

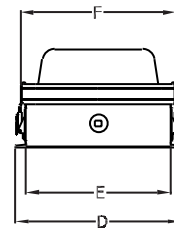
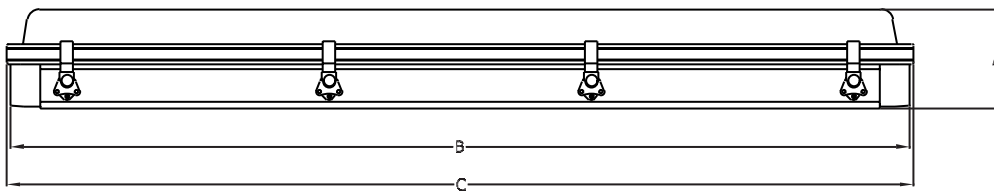
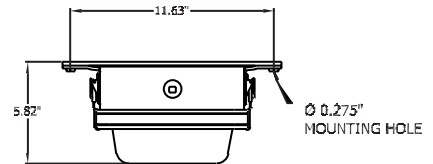
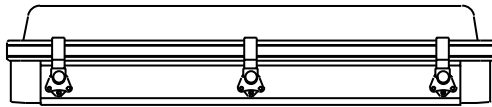

Nominal Length	Dimensions in Inches / Centimeters						Carton W x D x L Inches	Nominal Weight	
	A	B	C	D	E	F		Lbs	Kg
2 Foot	5.6 / 15.3	27.4 / 69.6	28.0 / 71.1	9.5 / 24.2	8.0 / 20.3	8.5 / 21.3	10 ½ X 6 ½ X 33	19.0	8.6
4 Foot	5.6 / 15.3	51.4 / 130.6	52.0 / 132.1	9.5 / 24.2	8.0 / 20.3	8.5 / 21.3	10 ½ X 6 ½ X 57 ½	29.0	13.2

MOUNTING OPTIONS

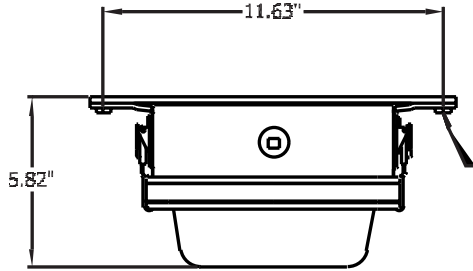

Ø 0.275"
MOUNTING HOLE

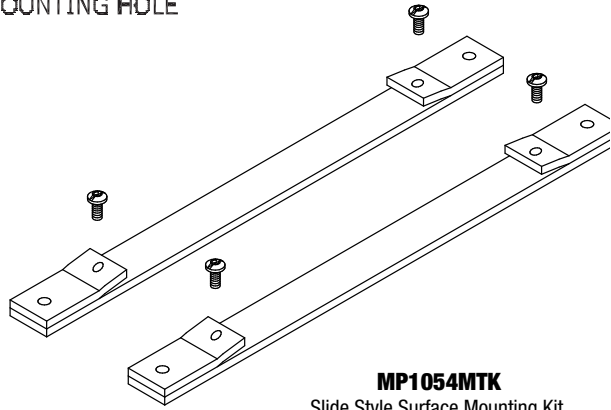

MP1054MTK
Slide Style Surface Mounting Kit.