

Pro

ProLamp FE/ml



FEATURES

- Base designed for permanent mounting, hardware included.
- Fixed or adjustable arm models.
- Impact resistant clear lens.
- Optional colored lenses available.
- Hinged lens frame allows transition between colored and white light.
- Push type momentary contact switch provided.
- Eight foot cord and plug supplied.

APPLICATIONS

- Fixed mount desk and chart
- Marine interior
- State room
- Office

APPROVALS

- Conforms to IP40
- Marine Inside Type
- ABS

STANDARDS

- UL 1598A - Luminaires for Marine Vessels

TECHNICAL SPECIFICATIONS

SHADE

Type 5052H32 aluminum housing with an electrostatically applied light gray polyester powder coat finish.

BASE

Die cast aluminum with an electrostatically applied light gray polyester powder coat finish.

END CAPS

Acrylonitrile butadiene styrene (ABS).

REFLECTOR

Type 5052H32 aluminum with an electrostatically applied white polyester powder coat finish. Minimum 90% reflectance.

LENS

Acrylic, clear. Optional, red or yellow.

LAMP HOLDER

Polycarbonate, Bi-Pin.

LAMP TYPE

Two 15w T8 Bi-Pin G13 fluorescent. Lamps not provided.

SWITCH

Push type momentary contact. Optional double pole toggle.

CORD AND PLUG

Three conductor SJT cord with NEMA 5-15P plug.

BALLAST

120v 60Hz.

ORDERING REFERENCES

PART NUMBER	DESCRIPTION	NO. LAMPS	WEIGHT LBS
FE215CV/5	Stationary Arms	2	7.0
FE215CV/6	Adjustable Arms	2	8.0

SPECIAL OPTIONS

- RV - Red Lens (Replace CV suffix)
- YV - Yellow Lens (Replace CV suffix)
- DS - Double Pole Toggle Switch
- L* - Lamps

*Lamps are not included unless option "L" is specified.

SPARE PARTS

Part No.	Description
FX5013	BALLASTS (2 required)
FX3508	LAMP F15T8
FX2111CLR	LENS, Clear
FX2111RED	LENS, Red
FX2111YEL	LENS, Yellow
FX4048	LAMP HOLDER
FX3029	SWITCH
INX3012	TOGGLE SWITCH

DIMENSIONS

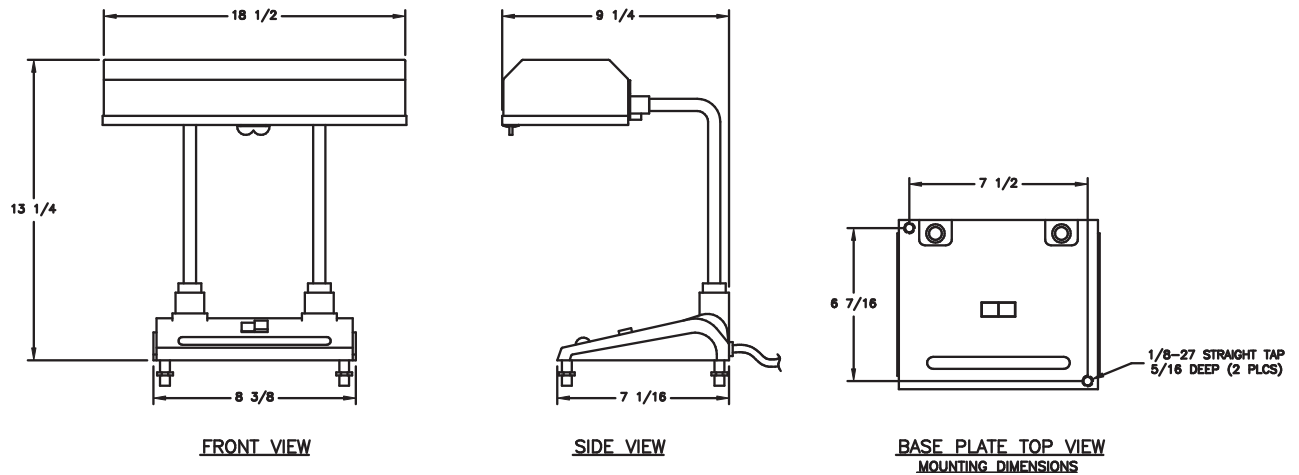

Dimensions in inches